

# SCAG®

## BELT DRIVE COMMERCIAL MOWERS TECHNICAL MANUAL

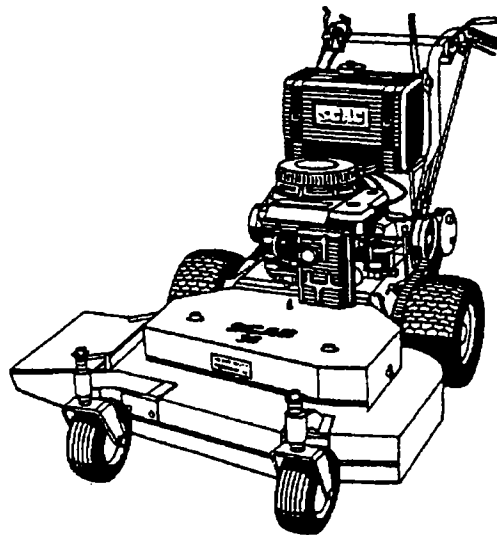

### MODELS

SW36-14KA  
SW36-14KH  
SW48-14KA  
SW48-14KH

SW-14KA  
SW-14KH  
SW-18KH  
SW-20KHE

SWM-52  
SWM-61  
SWM-72

PATENT NO. 4,885,903

© 1991  
SCAG POWER EQUIPMENT, INC.  
SUBSIDIARY OF METALCRAFT OF MAYVILLE

PART NO. 01140  
PRINTED 11/91  
PRINTED IN USA

# TABLE OF CONTENTS

**SUBJECT**

<b>Safety Instructions</b>	
Before Operating _____	2
While Operating _____	2
While Maintaining and Storing _____	3
<b>Assembly Instructions</b> _____	3-5
<b>Adjustments</b>	
Cutter Deck Drive _____	6
Drive Controls _____	6
Cutter Deck _____	6
Transmission Drive Belt _____	7
Tire Pressures _____	7
General _____	8
<b>Lubrication</b> _____	9
<b>Maintenance</b> _____	9
<b>Initial Run-In</b> _____	10
<b>Operating Instructions</b> _____	10
<b>Illustrated Parts Listings</b>	
36" Cutter Deck _____	13-14
48", 52", 61" & 72" Cutter Decks _____	15-16
Engine Deck _____	17-19
Transmission _____	20
Handle Assembly _____	21-23
Wiring Diagram Electric Start _____	24
Wiring Diagram Manual Start _____	25
Replacement Decals _____	26
<b>Warranty</b> _____	27



## **SAFETY INSTRUCTIONS**

Your mower is only as safe as the operator! As with any type of power equipment, carelessness or error on the part of the operator may result in serious bodily injury. In addition, improper maintenance of the machine can also result in injury. To reduce the potential for injury, please read and follow these instructions on safe operation and be certain that anyone using this mower fully understands and complies with the following instructions.

### **BEFORE OPERATING**

1. Read and understand the contents of this Technical Manual before operating the machine. Become familiar with all controls and know how to stop quickly. A free replacement manual is available by sending complete Model and Serial Number to:

Scag Power Equipment, Inc.  
1000 Metalcraft Drive  
Mayville, WI 53050

2. Do not allow children to operate the machine. Do not allow adults to operate the machine without proper instruction.
3. Before attempting to start engine, shift transmission into neutral, move blade clutch lever into STOP position and move neutral latches to NEUTRAL LOCK.
4. Remove all debris or other objects that might be picked up and thrown by the cutter blades. Keep all bystanders away from the mowing area.
5. Keep all shields, safety devices, and decals in place. If a shield, safety device or decal is defective or damaged, repair or replace it before operating. Also, tighten all loose nuts, bolts and screws to assure machine is in safe operating condition.
6. Do not operate machine while wearing sandals, tennis shoes, sneakers or shorts. Also, do not wear loose fitting clothing which could get caught in moving parts. Always wear long pants and substantial shoes. Wearing safety glasses and safety shoes is advisable and required by some local ordinances and insurance regulations.
7. Fill fuel tank with gasoline before starting the engine. Avoid spilling gasoline. Since gasoline is flammable, handle it carefully.
  - A. Use an approved gasoline container.
  - B. Do not fill tank while engine is hot or running.
  - C. Do not smoke while handling gasoline.
  - D. Fill fuel tank outdoors and up to about one inch (25 mm) below the bottom of the filler neck.
  - E. Wipe up any spilled gasoline.

### **WHILE OPERATING**

8. Start engine when neutral latches are in neutral lock position, cutter blades are disengaged, and transmission is in neutral.
9. Do not run the engine in a confined area without adequate ventilation. Exhaust fumes are hazardous and could possibly be deadly.
10. Using the machine demands attention. To prevent loss of control:
  - A. Mow only in daylight or when there is good artificial light.
  - B. Watch for holes or other hidden hazards.
  - C. Do not drive close to a drop-off, ditch or creek bank or other hazard.
  - D. Reduce speed when making sharp turns and when turning on hillsides.
  - E. Always be sure of your footing. Keep a firm hold on the handle and walk—never run.
  - F. Do not operate where conditions are slippery.
11. The discharge chute must always be installed and in the down position on the side discharge cutting unit except when optional grass catcher or mulching plate are completely installed. If the cutting unit discharge should plug, shut engine off and wait for all movement to stop before removing obstruction.
12. Disengage the blades and wait for them to stop before crossing gravel drives, walks or roads.
13. Shut the engine off and wait until the blades come to a complete stop before removing the grass catcher container.
14. Never raise the cutting unit while the blades are rotating.
15. If the cutting blades should strike a solid object or the equipment should start to vibrate abnormally, stop the engine, disconnect the spark plug wire, and check immediately for the cause. Vibration is generally a warning of trouble. Check the cutting unit and traction unit for damaged or defective parts. Repair any damage before starting the engine and operating the cutter unit. Be sure blades are in good condition and blade bolts are tight.
16. Always park the mower and/or start the engine on a level surface. If this is not possible, block the wheels to prevent the mower from moving when you are not in the operator's position.
17. Cut grass slopes carefully. Do not start, stop or turn suddenly. Mow across the face of slopes; never up or down. Do not mow excessively steep slopes.

## **SAFETY INSTRUCTIONS CONT'D**

18. Do not touch engine or muffler while engine is running or soon after it is stopped. These areas could be hot enough to cause a burn.
19. Before leaving the operator's position or leaving mower unattended, shift transmission into NEUTRAL, place neutral latches in NEUTRAL LOCK position, move cutter blade engagement lever to STOP and shut OFF engine.
20. Do not pass or stand on the grass discharge side of any mower with the engine running. Stop operation when another person approaches.

### **MAINTENANCE AND STORAGE**

21. Disconnect high tension wire from spark plug to prevent accidental starting of the engine when servicing, adjusting or storing the machine.
22. If mower must be tipped to perform maintenance or adjustment, remove battery, drain gasoline from fuel tank and oil from crankcase.
23. To reduce potential fire hazard, keep the engine free of excessive grease, grass, leaves and accumulations of dirt.
24. Be sure machine is in safe operating condition by keeping nuts, bolts, and screws tight. Check the blade mounting bolts and nuts frequently to be sure they are tightened.
25. If the engine must be running to perform a maintenance adjustment, keep hands, feet, clothing and other parts of the body away from the cutting unit blades and other moving parts.
26. Do not overspeed the engine by changing governor settings. To be sure of safety and accuracy, have an authorized dealer check maximum engine speed with a tachometer.
27. Engine must be shut off before checking oil or adding oil to the crankcase.
28. Allow engine to cool before storing mower in any enclosure such as a garage or storage shed. Make sure the mower fuel tank is empty if machine is to be stored in excess of 30 days. Do not store mower near any open flame or where gasoline fumes may be ignited by a spark.
29. Always store gasoline in a safety-approved, red container.
30. Keep the mower and fuel container in locked storage to prevent children from playing and tampering with them.

31. Perform only those maintenance instructions described in this manual. If major repairs are ever needed or assistance is desired, contact an Authorized Scag Dealer. To ensure optimum performance and safety, always purchase genuine SCAG replacement parts and accessories. NEVER USE "WILL-FIT" replacement parts and accessories made by other manufacturers. Using unapproved replacement parts and accessories may void the warranty.
32. Be careful when servicing the battery as it contains acid, which is corrosive and could cause burns to skin and clothing.
33. Batteries release explosive gasses when being charged or discharged. KEEP away from any source of sparks and/or flame.

## **ASSEMBLY INSTRUCTIONS**

### **ELECTRIC START UNITS ONLY!**

Before proceeding with assembly prep the battery. Fill each cell with electrolyte until the top of the plates are covered, charge the battery at 3 to 4 amps for 4 hours (this insures a good initial charge), check and add electrolyte as needed to bring the fluid level to the bottom of the split ring, and then wash and dry off the battery.

**NOTE:** *Once the above fill and charge procedure has been completed only distilled water should be added to the battery cells.*

Set the battery into the support, connect the positive cable to the positive post, then connect the negative cable to the negative post, put the battery cover in place (at the back of the battery), and clamp the battery into place (finger tight) using the carriage bolts and wing nuts **DO NOT OVER TIGHTEN.**

**⚠ WARNING:** Severe chemical burns can result from improper handling of battery electrolyte. Use proper eye, skin and clothing protection to prevent contact with eyes, skin and clothing.

External contact: Flush with water.

Internal contact: Drink large quantities of water, followed with milk of magnesia, beaten egg or vegetable oil.

**CALL A PHYSICIAN IMMEDIATELY!**

**IMPORTANT -** In case of internal contact **DO NOT** give fluids that would induce vomiting.

Eye contact: Flush with water for at least 15 minutes and **GET MEDICAL ATTENTION IMMEDIATELY!**

## ASSEMBLY INSTRUCTIONS CONT'D

**⚠ WARNING:** Explosive gases are vented from a battery when being charged or discharged which could explode if exposed to a flame or spark.

### SET-UP ALL UNITS

1. Lay out hardware according to the "Where Used" list in the loose parts packing list.
2. Install handle assembly to handle mounting frame using four 3/8-16 x 1" bolts, flat washers, and elastic stop nuts. Three different handle heights can be obtained using one of the three slotted holes in the handle mounting frame.
3. Route the throttle control above the RH jackshaft and up the right side of handle. Secure to handle with 1/4-20 x 2" hex head bolt and elastic stop nut. Secure cable about half way down the handle using a cable tie.

**NOTE:** Check that the throttle cable moves the carburetor controls through their full range. If not adjust as required.

4. Route the safety interlock wires up the left handle tube and attach the connector to the switch as shown. Be certain that the connector does not hit the safety lever stop tab, if it does, rotate the switch to the position shown (see fig. 1).

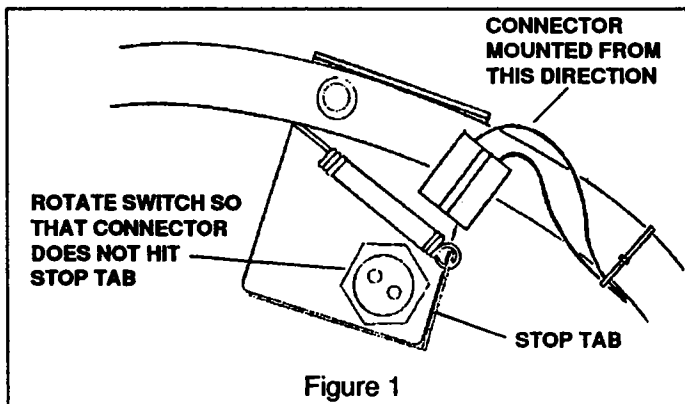

Figure 1

5. Installing control rods.
  - a) Thread rods into the swivel joints that are attached to the idler brackets on each side of the unit.
  - b) Adjust the rods so that there is about a 1/4"-3/8" clearance to the bottom of the neutral latch slot when in the drive position. Secure with small hair pin cotter as shown (see fig. 2)

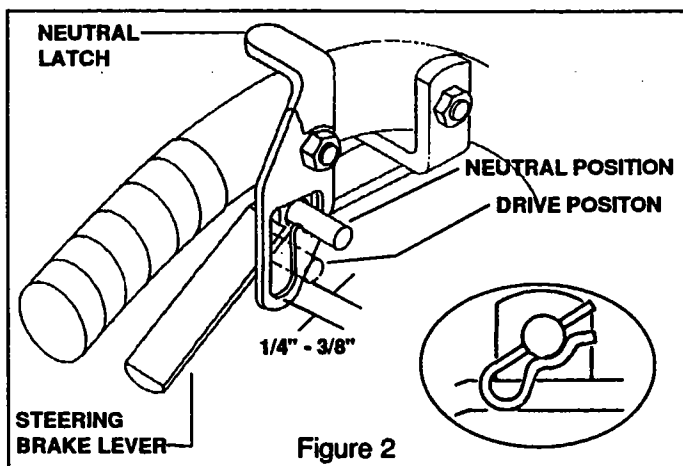

Figure 2

- c) Adjust brake rods so the brakes lock when the steering levers are pulled all the way up.

**NOTE:** Rods must allow neutral latches to be moved to the neutral position. (see fig. 2)

6. Attach shift lever assembly as shown (see fig. 3) on top of the short lever that is bolted to the transmission using two 5/16-18 x 1" bolts, flat washers, lock washers and hex nuts. The heavy flat washers should be under the shift lever. The two bars should be parallel after bolts are tightened.

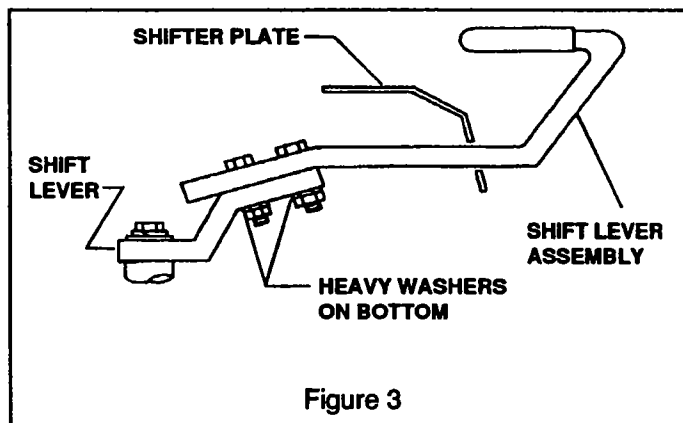

Figure 3

7. The shift plate should be adjusted so that the shift lever assembly is 0 to 1/8" away from the stop when the transmission is in neutral (see fig. 4). Tighten nuts securely.
 

**NOTE:** Engine will not start if transmission is not in neutral.

## ASSEMBLY INSTRUCTIONS CONT'D

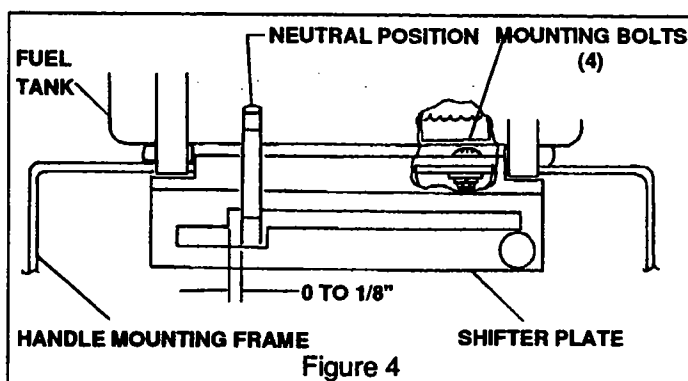

Figure 4

8. Attach fuel tank (See figure 5) as follows:
  - a) Wrap the straps around the fuel tank to pre-form them, then set aside to be used later.
  - b) Position the four rubber pads on to the gas tank. 2 - 1/4" thick pads in the strap grooves on top and 2 - 3/8" pads with adhesive bottoms in the strap grooves between the gas tank and handle mounting frame. Attach the adhesive side of the bottom two pads to the handle mounting frame.
  - c) Position the tank so the SCAG logo is forward. Place the straps around the tank going under the handle mounting frame, secure the strap together in front using (2) two 1/4-20 x 2" slotted machine screws and hex nuts. Tighten screws until the tank will not slide around. Over tightening will damage the tank or straps.
  - d) Attach the fuel line to the valve on the bottom of the tank.

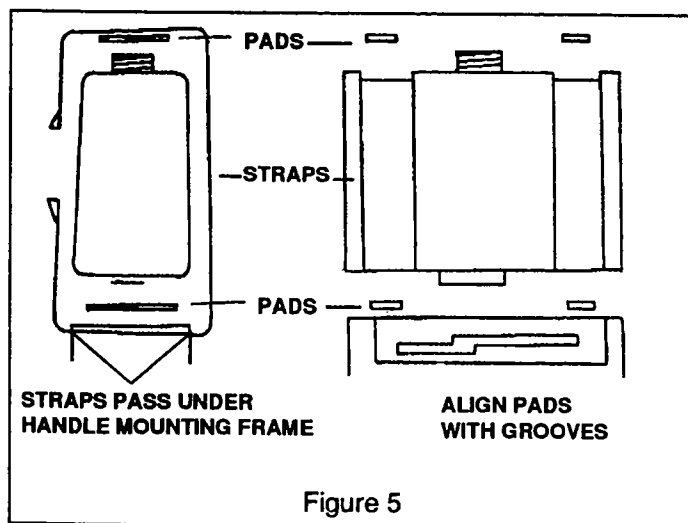

Figure 5

### ATTACHING SW52, SW61, OR SW72 TO ENGINE DECK

- a) Before beginning, determine which mounting holes are to be used to best suit the cutting height requirements of your customer. High/Medium/Low ranges (see fig. 6).

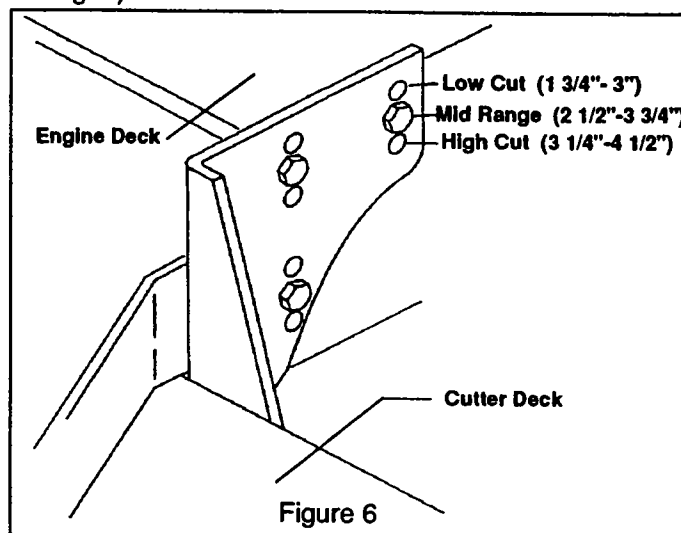

Figure 6

- b) Remove belt cover by loosening the wing nuts securing it to the cutter deck.
  - c) Position the cutter deck so that the engine deck is between the mounting brackets of the cutter deck. Install two bolts through the mounting holes selected, secure loosely with a flat washer, lock washer and hex nut. Tilt the engine deck up or down to align the remaining four holes and secure with remaining hardware.
  - d) Torque cutter deck mounting bolts to 50 to 70 ft. lbs..
  - e) Route belt around engine pulley and tighten bolt on engine belt guide. Connect lower blade clutch control rod to eyebolt and over center link with flat washer and hair pin.
10. Attach discharge chute to cutter deck using two 5/16-18 x 1" bolt and elastic stop nuts. Tighten bolts on chute until chute moves freely with some resistance.
  11. Attach caster wheels supports to cutter deck using four 5/16-18 x 3/4" bolts, lock washers and hex nuts.
- NOTE:** Check all hardware to be sure it is tightened properly, also check clearance and routing of drive belts.
12. Check engine oil level and fill as is necessary. Add oil to the engine crankcase using type specified in engine operator's manual.
- 5 13. Fill fuel tank to about 1" below the fill neck with gasoline as specified in engine operator's manual.

## ADJUSTMENTS

### CUTTER DECK DRIVE ADJUSTMENTS

1. Engage blade clutch lever and check for proper over center clearance. There should be about 3/8" between rod and straight edge (see figure 7). Bend the stop tab to adjust clearance.

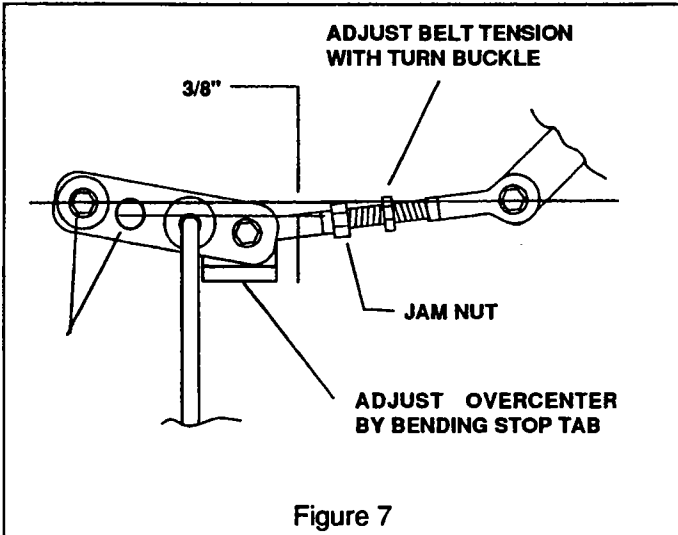

Figure 7

There are two holes drilled in to the cam link that you can use for the bolt that secures the cam link to the mounting post welded to the deck. This will allow you to lengthen or shorten the engagement linkage to compensate for belt wear.

2. Adjust belt tension so that the belt moves 1/2" with 10 lbs. of pressure applied between the center and left spindle pulleys (see figure 8). Adjustment is made by loosening the jam nut and tightening/loosening the turnbuckle (see figure 7). Belt driving right spindle should be checked the same way. Adjust with J-rod on RH belt tension adjustment idler.

**NOTE:** Belt tension may need to be increased or decreased 1 to 2 lbs. to achieve lowest vibration in belt.

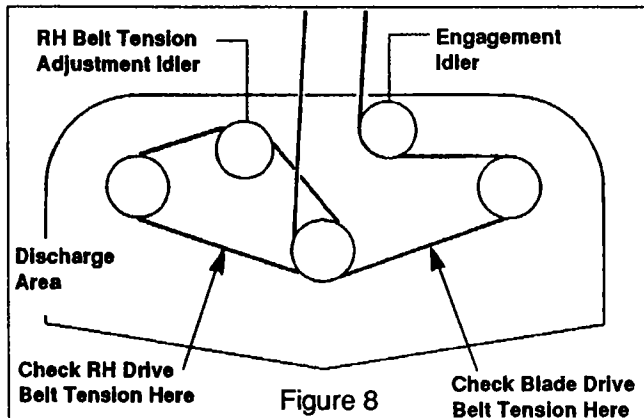

Figure 8

### DRIVE CONTROLS

1. Steering control rods should have about 1/4" clearance between the bottom of the slot and the bottom of the rod when the steering levers are released (See fig. 2).
2. The brake rods should be adjusted so that the brakes do not apply until the steering levers are pulled tight to the handles. When the steering levers are locked in the neutral position the unit may be pushed around.
3. The shift lever is not adjustable, however the shift plate can be moved right to left allowing proper positioning for neutral (See fig. 4).

### TRANSMISSION DRIVE BELT

Adjust the transmission drive belt so that there is about a 3/16" deflection with 10 pounds of pressure. Adjust by loosening idler pulley mounting bolt and sliding the idler left or right to change belt tension.

### TIRE PRESSURES

Drive Wheel Tires	15 psi
Caster Wheels	25 psi

### GENERAL ADJUSTMENTS

1. Check that all belts clear their guides by 1/8" to 1/4".
2. Adjust tension of blade drive belt by rotating turnbuckle so that about 10 pounds pull sideways deflects belt about a 1/2". **DO NOT OVERTIGHTEN.** Only a moderate force should be required on the engagement lever.
3. Check tension of transmission drive belt (under engine deck). A ten pound pull sideways should deflect belt about 3/16". Slide idler pulley if required to adjust.
4. The tension of the two Twin Power Wheel Drive belts is self-adjusting. However, for adequate declutching, adjust length of steering control rods on each side of handle until about a 1/4" gap is provided between rod and bottom of neutral latch slot, when neutral latch is in drive position.
5. Adjust brake rods so that brakes will lock wheels while pulling machine rearward with steering levers fully squeezed. Check that machine rolls freely when neutral latches are in neutral lock position.

## ADJUSTMENTS

### CUTTER DECK ADJUSTMENTS

Due to the many conditions that exist, it is difficult to suggest a setting that will work for every lawn. There are two adjustments that can be made on these decks, pitch and height.

**PITCH** is the angle of the blades (comparing front to rear). A *positive pitch* is when the front (leading) edge of the cutting plane is lower than the rear (trailing) edge, *level pitch* is when both front and rear are the same height, a *negative pitch* is when the leading edge is higher than the rear edge. We suggest that a positive pitch be used when cutting grass. The front of the deck should be 1/4" to 1/2" lower than the rear of the deck.

**HEIGHT** is the nominal distance the blade is off of the ground. This measurement is made with the blades pointed side to side and distance is measured between cutting tip and ground.

### BALL BEARING SPINDLE ASSEMBLY

Adjusting the blade height can be done by moving any number of the five spacers on the blade mounting bolts to the top of the spindle shaft or below the spindle shaft (all blades should be positioned equally). Unit is shipped with one spacer on top and four underneath (see figure 9). For best cut and discharge a minimum of three spacer should be between the blade and spindle.

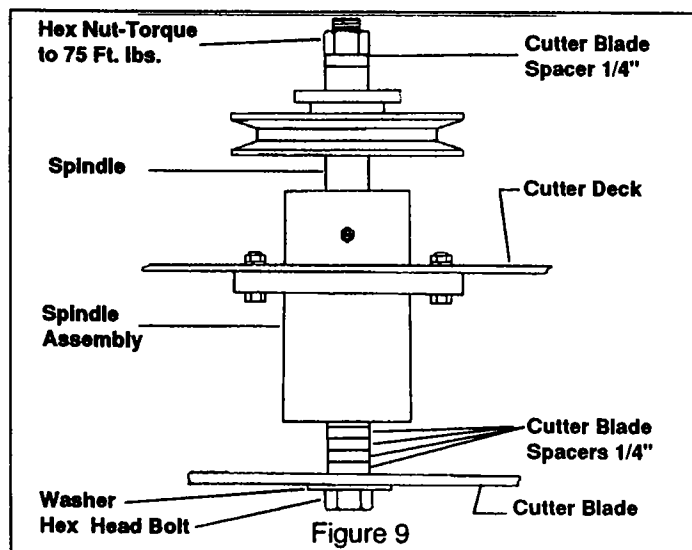

### TAPERED BEARING SPINDLE ASSEMBLY

Adjusting the blade height can be done by moving any number of the four smaller 1/4" spacers on the blade mounting bolts to the top of the spindle shaft or below the spindle shaft. (All blades should be positioned equally). The tapered bearing spindle has a large 1/4" spacer that is installed directly below the spindle housing and is secured to the spindle with two roll pins. The blade can be adjusted all the way up to the spindle assembly if all the smaller 1/4" spacers are removed and installed above the pulley. The larger 1/4" spacer can then be removed along with the roll pins. (Do not install the larger 1/4" spacer above the pulley, store it in a convenient location away from the machine). When any 1/4" spacers are installed above the blades the larger 1/4" spacer must be installed directly below the spindle housing. If a smaller 1/4" spacer is installed directly below the spindle housing and contacts the retaining ring this will cause a spindle failure and not be warrantable. For best cut and discharge a minimum of three spacers should be between the blade and spindle. (SEE FIGURE 10)

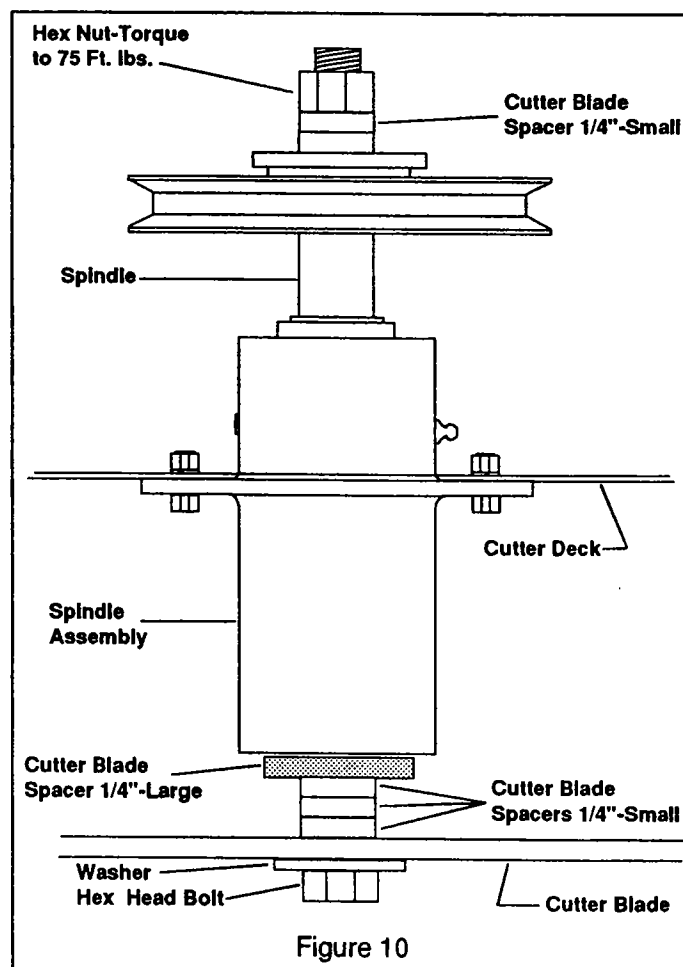



## ADJUSTMENTS CONT'D

Additional range to the cutting height can be achieved by repositioning the cutter deck in relationship to the engine deck (This adjustment can also effect the pitch of the deck). There are 3 positions (see figure 6), suggested mounting is the middle holes. For cutting lower, mount the deck in the top holes. To cut higher, mount the deck in the bottom holes.

Remember to check the cutter deck belt alignment. Shimming or attaching the idler mounting bracket from underneath may be necessary to maintain belt life.

Caster spacers also can be repositioned to change cutting heights and to change the pitch of the deck (see figure 11).

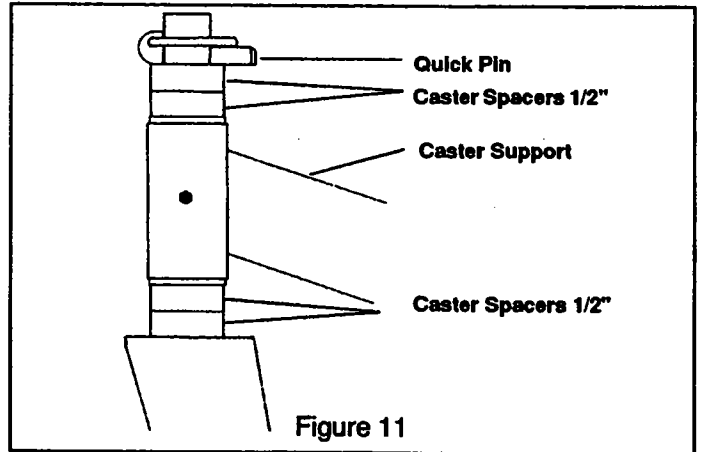

## LUBRICATION & MAINTENANCE

		BREAK-IN	
		8 HOURS (DAILY)	
		40 HOURS (WEEKLY)	
		100 HOURS (BIWEEKLY)	
		200 HOURS (MONTHLY)	
	PROCEDURE	COMMENTS	
X	Check all hardware for proper tightness		
X	Change engine oil and filter at 5 hours		
X	Check engine oil	Do not over fill	
X	Remove debris from under belt cover	More often if needed	
X	Sharpen cutter blades	More often if needed	
X	Grease spindle bearings 2 pumps of hand gun	+ US Lithium MP White Grease 2125	
X	Clean air filter	More often if needed	
X	Check tire pressure	Add or adjust as required	
X	Change engine oil	See engine mfg. information	
X	Replace air filter - quality	More often if needed	
X	Grease caster wheel bearings	Chassis grease	
X	Grease caster wheel pivot shafts	Chassis grease	
X	Grease idler pulley bracket pivot bearings	Chassis grease	
X	Grease drive wheel bearings	Chassis grease	
X	Grease traction idler pivot	Chassis grease	
X	Grease Idler bracket LH & RH	Chassis grease	
X	Grease brake lever pivot	Chassis grease	
X	Grease transmission couplers	Chassis grease	
X	Check all hardware for proper tightness		

+ Grease spindle until grease comes out the relief valve

## INITIAL RUN-IN

**⚠ WARNING:** Use extreme caution during mower's initial run-in to assure caster wheels are adequately blocked and drive wheels do not inadvertently contact ground. Keep bystanders away from machine. Never allow mower to discharge towards someone. Never leave the machine unattended during the initial run-in.

1. Lubricate all fittings as specified in Lubrication Section.
2. Locate machine in a secure area, away from bystanders, and preferably facing a wall. Raise drive wheels off ground. Block caster wheels.
3. Start engine and shift transmission into fourth gear. Engage cutter blades. Set throttle for 3/4 of full engine rpm.
4. Run the machine for a few minutes.
5. Declutch cutter blades, shift transmission into NEUTRAL, Stop engine.
6. Check tension of blade drive belt(s) and transmission drive belt. Adjust if necessary.
7. If necessary, readjust steering control and brake rods as indicated in the Adjustments Section.
8. Check function of all safety interlocks. Make sure that engine will not start unless transmission is in neutral and blade clutch is disengaged.
9. Check tire pressure and adjust to:

Caster Wheels	25 psi.
Drive Wheels	15 psi.

YOU ARE NOW READY FOR MOWING WITH  
CONFIDENCE!

## OPERATING INSTRUCTIONS

1. Read and understand the instructions on safety before attempting to operate.
2. Before starting engine:
  - \* Fuel valve must be opened.
  - \* Transmission must be in NEUTRAL.
  - \* Blade clutch lever must be in STOP position.
  - \* Neutral latches must be in NEUTRAL LOCK position.
  - \* Key switch on.
  - \* Choke as required.
3. Start engine. Adjust throttle to achieve proper blade speed.
4. Engage cutter blades by pushing blade clutch lever forward until it snaps into the on position. Pull lever back to disengage cutter blades.
5. Shift transmission into gear for desired mowing speed.

**NOTE:** *Top speed is suggested only for transport!*

6. While squeezing steering brake levers with both hands, release both neutral latches.
7. When steering brake levers are released, machine will travel straight. To make a right turn, squeeze RH lever to turn left squeeze LH lever.
8. TO STOP wheel drive, squeeze both levers, lock neutral latches, shift transmission into neutral.

**⚠ WARNING:** To avoid serious bodily injury and damage to transmission, machine must be at full stop before shifting from forward to reverse or from reverse to forward.

9. In reverse gear, the steering brake levers must be pushed downward for maximum traction.

## 36" CUTTER DECK

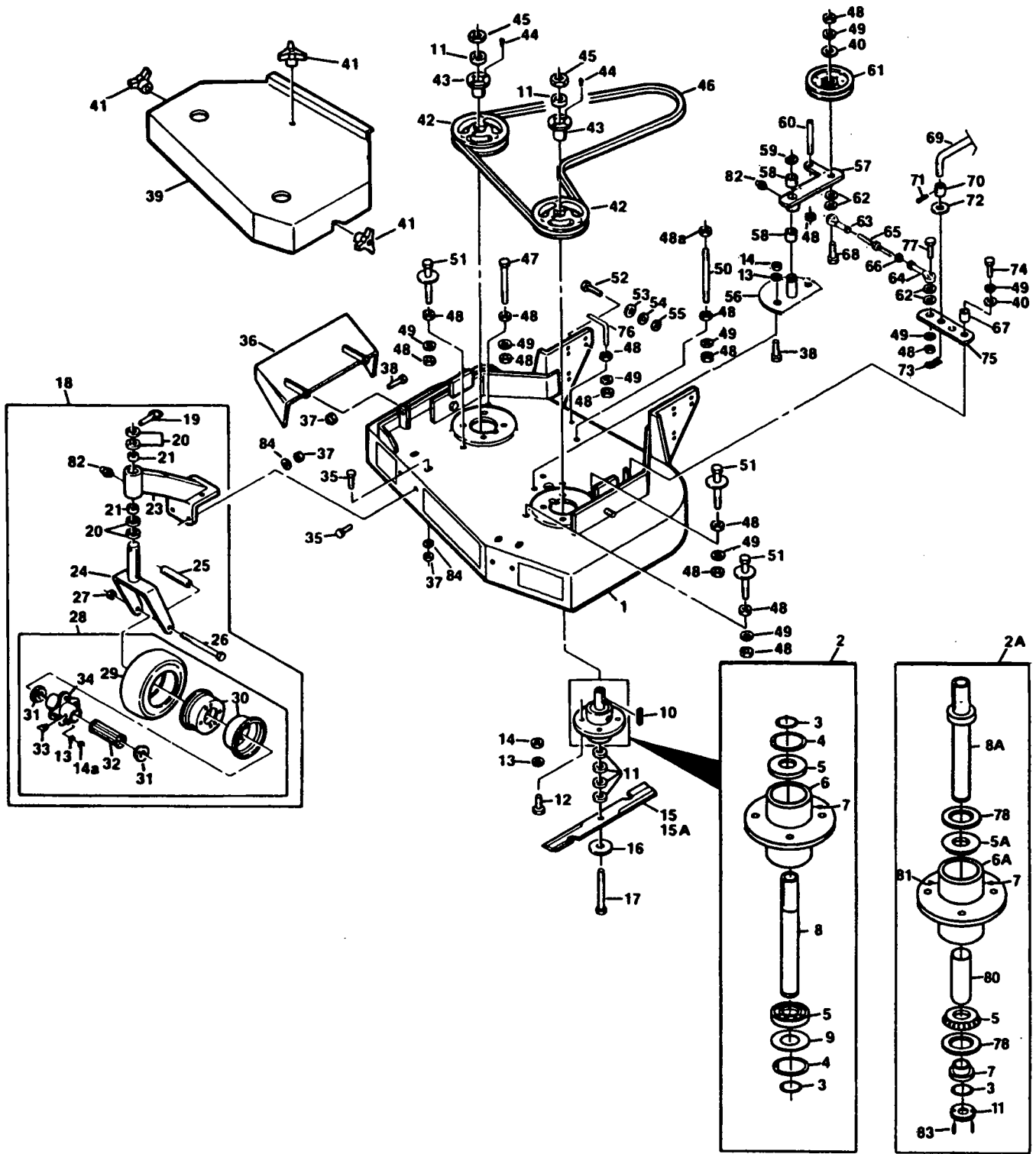

## 36" CUTTER DECK

Ref. Part No. Number	Description	Ref. Part No. Number	Description		
1	46397	Cutter Deck (Includes Decals)	40a	*	Washer, 13/32 x 13/16 x 16 ga.
2	46020	Cutter Spindle Assy. (Includes Items 3-9)	41	04029-03	Wing Nut, 3/8-16
2A	46400	Cutter Spindle Assy.	42	48127	Pulley (Includes Items 43-44)
3	04050-04	Retaining Ring, 1" Ext.-Inverted	43	48141	Tapered Hub
4	04050-07	Retaining Ring, 2-7/16 Int.bsc	44	*	Hex Hd. Bolt, 1/4-20 x 3/4
5	48101-02	Bearing, Spindle	45	*	Hex Nut, 5/8-11
5A	48668	Tapered Bearing	46	48204	Belt, Blade Drive
6	41001	Spindle Housing	47	*	Hex Hd. Bolt, 3/8-16 x 5
6A	41007	Spindle Housing	48	*	Hex Nut, 3/8-16
7	48114-02	Grease Fitting, Str., 5/16 Serr	48a	*	Hex Nut, 3/8-16 Ctr Locknut
8	43001-02	Spindle, Cutter Blade	49	*	Lockwasher, Spring 3/8
8A	45391	Spindle Shaft	50	04004-02	Support, Belt Cover
9	04041-02	Washer, 1-5/16 x 2-7/16 x 16 ga.	51	45098	Belt Guide
10	04063-08	Key, 1/4 x 1/4 x 2	52	*	Hex Hd. Bolt, 7/16-14 x 1-1/4
11	43038	Spacer, Cutter Blade - Small	53	*	Washer, 15/32 x 59/64 x 16 ga.
11A	43201	Spacer, Cutter Blade - Large	54	*	Lockwasher, Spring, 7/16
12	*	Hex Hd. Bolt, 5/16-18 x 1-1/4	55	*	Hex Nut, 7/16-14 Elastic Stop
13	*	Lockwasher, Spring, 5/16	56	45423	Idler Pivot
14	*	Hex Nut, 5/16-18	57	46434	Idler Arm Assy. (Includes Items 62 & 58)
14a	*	Hex Nut, 5/16-24	58	48100-02	Bronze Bearing
15	48108	Cutter Blade 18"	59	04050-05	Retaining Ring, 1 1/8" Ext.,"E"
15a	48185	Cutter Blade 18" Hi Lift	60	04004-04	Stud
16	04040-10	Flat Washer, 5/8 W	61	48269	Idler Pulley, Belt Clutch
17	04001-41	Hex Hd. Bolt, 5/8-11 x 9-1/2	62	*	Flat Washer, 3/8"
18	46079	Caster Assembly (Includes Items 19-28)	63	48544	Rod End - L.H. Thd (Silver)
19	04066-01	Quick Pin	64	48464	Rod End - R.H. Thd (Gold)
20	43037-01	Spacer, Caster Yoke, 1/2" long	65	48590	Link, Turnbuckle
21	48100-01	Bronze Bearing	66	*	Hex Nut, 3/8-24
23	46082	Support Assembly (Includes Items 21, 82)	67	43042	Sleeve, Clutch Rod
24	45006	Caster Yoke	68	*	Hex Hd. Bolt, 3/8-16 x 2-3/4
25	43022	Sleeve, Caster Wheel Brg.	69	44064	Blade Clutch Rod, Lower
26	04001-37	Hex Hd. Bolt, 1/2-13 x 5-1/2	70	43043	Sleeve, Clutch Rod
27	*	Hex Locknut, 1/2-13	71	*	Cotter Pin, 3/32 x 1
28	48307	Wheel Assy. (Includes 13-14a, 29-34)	72	*	Washer, 33/64 x 1 x 16 ga.
29	48307-02	Tire Only Caster Wheel	73	04062-01	Hair Pin, Large
NS	48006-03	Inner Tube only	74	*	Hex Hd. Bolt, 3/8-16 x 1
30	48307-04	Rim Pair, Caster Wheel	75	421107	Cam Link
31	48006-07	Retainer, Bearing, Caster Wheel	76	44009	Belt Guide
32	48006-06	Roller Bearing, Caster Wheel	77	*	Hex Head Bolt, 3/8-16 x 1 1/2"
33	48114-03	Grease Fitting, 45' 1/4-28	78	48681	Seal, Cutter Spindle
34	48006-05	Hub Assembly	79	43217	Spindle Bushing
35	*	Hex Hd Bolt, 5/16-18 x 1"	80	43218	Sleeve, Cutter Spindle
36	45100	Discharge Chute	81	48677	Relief Fitting, Cutter Spindle
37	*	Hex Nut, 5/16-18 Elastic Stop	82	48114-04	Grease Fitting, Cutter Spindle
38	*	Hex Hd Bolt, 5/16-18 x 1	83	*	Roll Pin, 1/8 x 1/2"
39	46085	Belt Cover Assembly (Includes Decal)	84	*	Flat Washer, 5/16"
40	*	Washer, 25/64 x 15/16 x 12 ga.			

\* Common hardware which should be purchased locally. All bolts are Grade 5 plated, all other fasteners are zinc plated.

## 48, 52, 61, & 72" CUTTER DECK

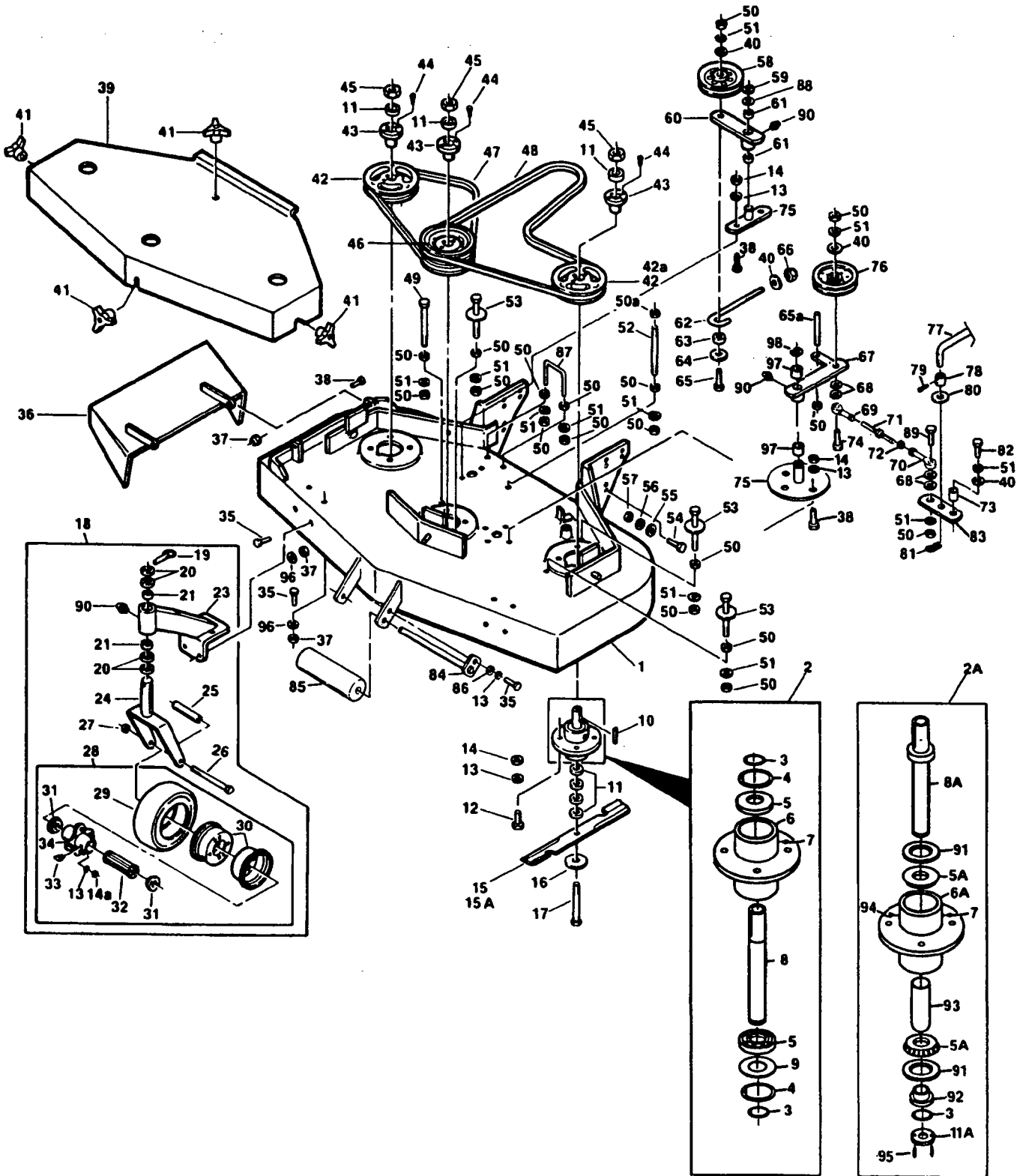

## 48, 52, 61, & 72" CUTTER DECKS

Ref. Part No.	Part No.	Description	48	52	61	72	Ref. Part No.	Part No.	Description	48	52	61	72
1	46088	Cutter Deck (Includes decals)	x				45	*	Hex Nut, 5/8-11	x	x	x	x
1	46163	Cutter Deck (Includes decals)		x			46	48412	Pulley, Double (Includes 43-44)	x	x	x	
1	46119	Cutter Deck (Includes decals)			x		46	48302	Pulley, Double (Includes 43-44)				x
1	46194	Cutter Deck (Includes decals)				x	47	48087	Belt, RH Blade Drive	x			
2	46020	Cutter Spindle Assy. Ball Bearing	x	x	x	x	47	48285	Belt, RH Blade Drive			x	
2A	46400	Spindle Assembly, Tapered Bearing	x	x	x	x	47	48265	Belt, RH Blade Drive				x
3	04050-04	Retaining Ring, 1" Ext.-Inverted	x	x	x	x	47	48295	Belt, RH Blade Drive				x
4	04050-07	Retaining Ring, 2-7/16" Int.basic	x	x	x	x	48	48089	Belt, Blade Drive	x			
5	48101-02	Bearing, Cutter Spindle	x	x	x	x	48	48286	Belt, Blade Drive		x		
5A	48668	Tapered Bearing	x	x	x	x	48	48264	Belt, Blade Drive				x
6	41001	Spindle Housing	x	x	x	x	48	48296	Belt, Blade Drive				x
6A	41007	Spindle Housing, Tapered Bearing	x	x	x	x	49	*	Hex Hd. Bolt, 3/8-16 x 5"	x	x	x	
7	48114-02	Grease Fitting Str. 5/16 Serr.	x	x	x	x	49	45098	Belt guide				x
8	43001-02	Spindle, Cutter Blade	x	x	x	x	50	*	Hex Nut, 3/8-16	x	x	x	x
8A	45391	Spindle Shaft, Tapper Bearing	x	x	x	x	50a	*	Hex Nut, 3/8-16, Centerlock	x	x	x	x
9	04041-02	Washer, 1-5/16 x 2-7/16 x 16 ga.	x	x	x	x	51	*	Lockwasher, Spring, 3/8	x	x	x	x
10	04063-06	Key, 1/4 x 1/4 x 2	x	x	x	x	52	04004-02	Support, Belt Cover	x	x	x	x
11	43038	Spacer, Cutter Blade	x	x	x	x	53	45098	Belt Guide	x	x	x	x
11A	43201	Spacer, Cutter Blade, Tapered Bearing	x	x	x	x	54	*	Hex Hd. Bolt, 7/16-14 x 1-1/2	x	x	x	x
12	*	Hex Hd. Bolt, 5/16-18 x 1-1/4	x	x	x	x	55	*	Washer, 15/32 x 59/64 x 16 ga.	x	x	x	x
13	*	Lockwasher, Spring, 5/16	x	x	x	x	56	*	Lock Washer, Spring, 7/16	x	x	x	x
14	*	Hex Nut, 5/16-18	x	x	x	x	57	*	Hex Nut, 7/16-14	x	x	x	x
14a	*	Hex Nut, 5/16-24	x	x	x	x	58	48181	Idler Pulley, "V" Groove	x	x	x	x
15	48110	Cutter Blade 16-1/2"	x				59	04050-02	Retaining Ring, 3/4" Ext."E"	x	x	x	x
15	48108	Cutter Blade 18"		x			60	46081	Idler Arm Assy. (Includes 82 & 61)	x	x	x	x
15	48111	Cutter Blade 21"			x		61	48100-05	Bronze Bearing	x	x	x	x
15	48112	Cutter Blade 24"				x	62	43028	J Rod, Idler Pull	x	x	x	x
15a	48184	Cutter Blade 16-1/2" Hi Lift	x				63	43077	Spacer, J Pull Rod	x	x	x	x
15a	48185	Cutter Blade 18" Hi Lift		x			64	04041-12	Washer, 3/8 x 1-1/2 x 16 ga.	x	x	x	x
15A	48304	Cutter Blade 21" Hi Lift			x		65	*	Hex Hd. Bolt, 3/8-16 x 2-1/4	x	x	x	x
16	04040-10	Flat Washer, 5/8" W	x	x	x	x	65a	04004-04	Stud	x	x	x	x
17	04001-41	Hex Hd. Bolt, 5/8-11 x 9-1/2"	x	x	x	x	66	*	Hex Nut, 3/8-16 Elastic Stop	x	x	x	x
18	46079	Caster Assy, Comp. (incl. 19-28)	x	x	x	x	67	46434	Idler Arm (Includes Items 97, 90)	x	x	x	x
19	04066-01	Quick Pin	x	x	x	x	68	*	3/8" Flat Washer	x	x	x	x
20	43037-01	Spacer, Caster Yoke, 1/2" thick	x	x	x	x	69	48544	Rod End L.H. THD. (Silver)	x	x	x	x
21	48100-01	Bronze Bearing	x	x	x	x	70	48454	Rod End R.H. THD. (Gold)	x	x	x	x
23	46082	Support Assy. (incl. 21-90)	x	x	x	x	71	48590	Link, Turnbuckle	x	x	x	x
24	45006	Caster Yoke	x	x	x	x	72	*	3/8"-24 Hex Nut	x	x	x	x
25	43022	Sleeve, Caster Wheel Bearing	x	x	x	x	73	43042	Sleeve, Cam Clutch	x	x	x	x
26	04001-37	Hex Hd Bolt, 1/2-13 x 5-1/2"	x	x	x	x	74	*	Hex Hd Bolt, 3/8-16 x 2-3/4	x	x	x	x
27	*	Hex Locknut, 1/2-13	x	x	x	x	75	45329	Idler Pivot	x	x	x	x
28	48307	Wheel Assy. (incl. 13-14, 29-34)	x	x	x	x	76	48269	Idler Pulley, Belt Clutch	x	x	x	x
29	48307-02	Tire only, Caster Wheel	x	x	x	x	77	44064	Blade Clutch Rod, Lower	x	x	x	x
	48006-03	Inner Tube only, Caster Wheel	x	x	x	x	78	43043	Sleeve, Clutch Rod	x	x	x	x
30	48307-04	Rim Pair, Caster Wheel	x	x	x	x	79	*	Cotter Pin, 3/32 x 1	x	x	x	x
31	48006-07	Retainer, Bearing, Caster Wheel	x	x	x	x	80	*	Washer, 33/64 x 1 x 16 ga.	x	x	x	x
32	48006-06	Roller Bearing, Caster Wheel	x	x	x	x	81	04062-01	Hex Pin Large	x	x	x	x
33	48114-03	Grease Fitting 45 deg, 1/4-28	x	x	x	x	82	*	Hex Hd Bolt, 3/8-15 x 1	x	x	x	x
34	48006-05	Hub Assy. (incl. bolts)	x	x	x	x	83	421107	Cam Link	x	x	x	x
35	*	Hex Hd. Bolt, 5/16-18 x 3/4"	x	x	x	x	84	45045	Roller Shaft	x	x	x	x
36	45029	Discharge Chute	x				85	48038	Guide Roller		x	x	x
36	45100	Discharge Chute		x			86	*	Flat Washer, 11/32 x 11/16 x 16 ga.		x	x	x
37	*	Hex Nut, 5/16-18 Elastic Stop	x	x	x	x	87	44008	Belt Guide	x	x	x	x
38	*	Hex Hd. Bolt, 5/16-18 x 1	x	x	x	x	88	*	Flat Washer, 3/4 x 1-1/4 x .035	x	x	x	x
39	46086	Belt Cover (Includes decals)	x				89	*	3/8-16 x 1 1/2" Hex Head Bolt	x	x	x	x
39	46164	Belt Cover (Includes decals)		x			90	48114-04	Grease Fitting	x	x	x	x
39	46121	Belt Cover (Includes decals)			x		91	46681	Seal	x	x	x	x
39	46312	Belt Cover (Includes decals)				x	92	43217	Spindle Bushing	x	x	x	x
40	*	Washer 25/64 x 15/16 x 12 ga.	x	x	x	x	93	43218	Sieve, Cutter Spindle	x	x	x	x
41	04029-03	Wing Nut, 3/8-16	x	x	x	x	94	48677	Relief Fitting, Cutter Spindle	x	x	x	x
42	48127	Pulley (Includes 43-44)	x	x	x	x	95	*	Roll Pin, 1/8 x 1/2"	x	x	x	x
42a	48299	Pulley (Includes 43-44)				x	96	*	Flat Washer, 5/16"	x	x	x	x
43	48141	Tapered Hub	x	x	x	x	97	48100-02	Bronze Bearing	x	x	x	x
44	*	Hex Hd. Bolt, 1/4-20 x 3/4	x	x	x	x	98	04050-05	Retaining Ring 1 1/8 Ext. "E"	x	x	x	x

## ENGINE DECK

**NOTE: Engine Deck (Item 17)  
Now Has Handle Mounting  
Frame Welded To It.**

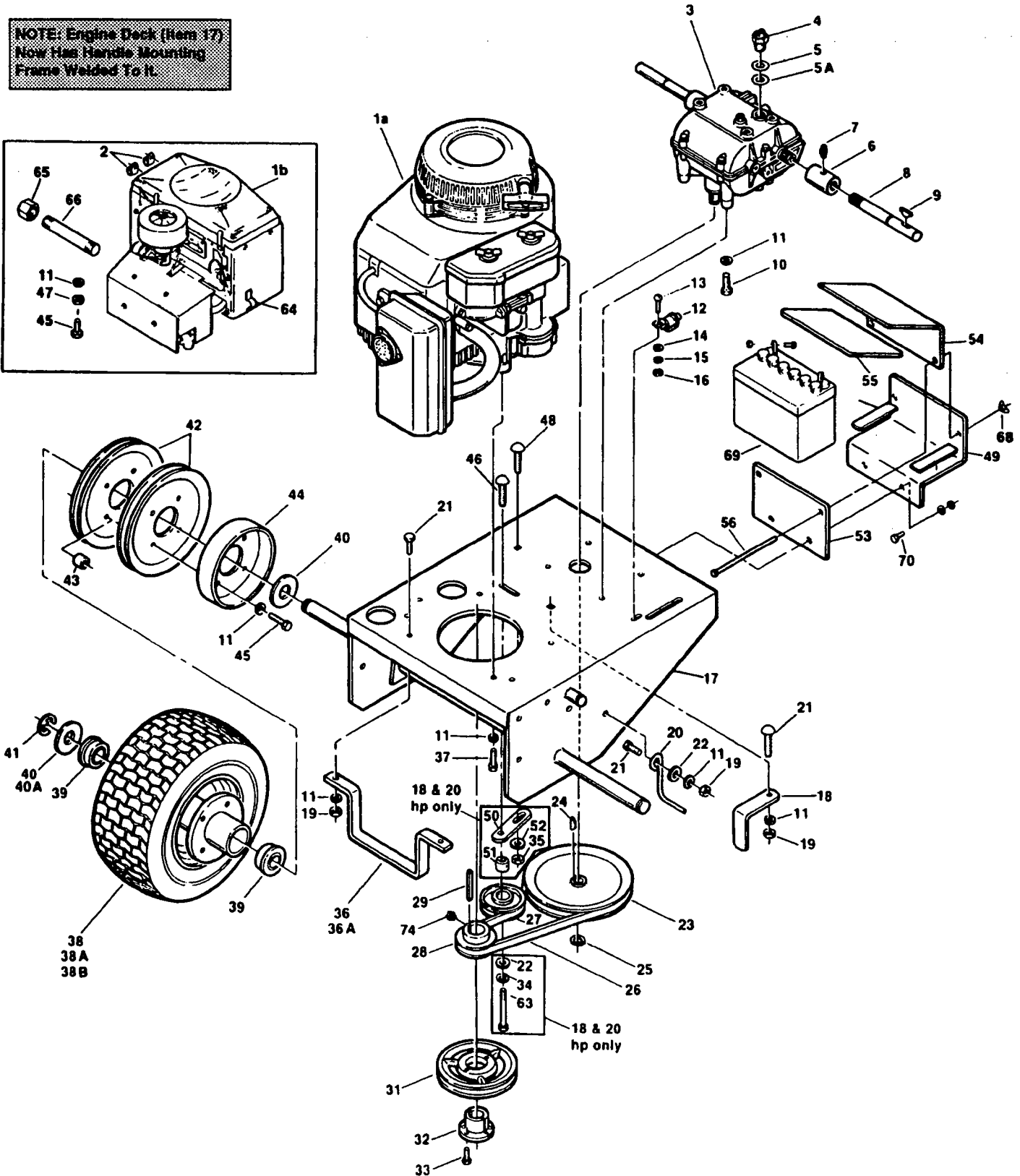

## ENGINE DECK

REF. PART NO.	DESCRIPTION	14BV	14KH	13KA	18KH	18EKH	20EKH
<b>! ATTENTION LINES IN BOLD LETTERS INDICATE EXTRA IDENTIFICATION IS NEEDED !</b>							
1a	48391 Engine 14HP Briggs Vanguard (261772 0120 01)	X					
1a	48357 Engine 14HP Kohler (CV12.5T PS-1413)		X				
1a	48190 Engine 12.5HP Kawasaki (FB460-ES05)			X			
1b	48268 Engine 18HP Kohler (MV18 PS-58511)				X		
1b	48268 Engine 18HP Kohler El. Sl. (MV18 PS-58568)					X	
1b	48358 Engine 20HP Kohler El. Sl. (MV20 PS-57568)						X
2	48059-01 Cable clamp					X	X
3	48331 Transmission, 5 spd. (Peerless 700-026)	X	X	X	X	X	X
4	48231 Neutral safety switch	X	X	X	X	X	X
5	48122-01 Fibre washer, thin	X	X	X	X	X	X
5a	48122-02 Fibre washer, thick	X	X	X	X	X	X
6	48226 Coupler, jackshaft	X	X	X	X	X	X
7	48114-01 Grease Ring, straight 1/4-28	X	X	X	X	X	X
8	48228 JACKSHAFT (FITS SW32, 36, & 48)	X	X	X			
8	48242 JACKSHAFT (FITS SW52, 61, & 72)		X	X	X	X	X
9	04063-09 Key, Hi-Pro #9	X	X	X	X	X	X
10	Hex Hd Bolt, 5/16-18 x 3/4	X	X	X	X	X	X
11	Lockwasher, Spring 5/16	X	X	X	X	X	X
12	48305 Switch, Clutch Safety black	X	X	X	X	X	X
13	Phillips Hd. Machine Screw, 10-32 x 1/2	X	X	X	X	X	X
14	Washer, 219 x .500 x .049	X	X	X	X	X	X
15	Lockwasher, #10 Ext. Tooth	X	X	X	X	X	X
16	Hex Nut #10-32	X	X	X	X	X	X
17	45090 ENGINE DECK (FITS SW36, & 48)	X	X	X			
17	45116 ENGINE DECK (FITS SW52, 61, 72)	X	X		X	X	X
17	45128 ENGINE DECK (FITS SW32)	X					
18	42199 Rear Belt Guide, Engine	X	X	X	X	X	X
19	Hex Nut, 5/16-18	X	X	X	X	X	X
20	44006 Belt Guide, Traction Dr.	X	X	X	X	X	X
21	Hex Head Bolt, 5/16-18 x 1	X	X	X	X	X	X
21a	Carriage Hd Bolt, 5/16-18 x 1	X	X	X	X	X	X
22	Washer, 25/64 x 15/16 x 12 ga.	X	X	X	X	X	X
23	48187 Pulley, Transmission Input	X	X	X	X	X	X
24	04063-07 Key, Woodruff #9	X	X	X	X	X	X
25	04050-09 Retaining Ring, 5/8 Ext. Basic	X	X	X	X	X	X
26	48203 Belt, Transmission Drive	X	X	X	X	X	X
27	48201 Idler Pulley, Transmission	X	X	X	X	X	X
28	48196 Pulley, Traction Drive	X	X	X	X	X	
28	48379 Pulley, Traction Drive						X
29	04063-03 Key, 1/4 x 1/4 x 2-1/2	X	X	X	X	X	X
31	48127 Pulley, Blade Dr. (Incl. 32-33)	X	X	X	X	X	
31	48378 Pulley, Blade Dr. (Incl. 31-33)						X
32	48141 Taper Hub (for 48127)	X	X	X	X	X	
32	48378-03 Taper Hub (for 48378)						X
33	Hex Hd Bolt, 1/4-20 x 3/4	X	X	X	X	X	X
34	Lockwasher, Spring, 3/8	X	X	X	X	X	X
35	Hex Nut, 3/8-16	X	X	X	X	X	
36	42268 BELT GUIDE, SADDLE (FITS SW32, & 36)	X	X	X			
36A	42265 BELT GUIDE, SADDLE (FITS SW48, 52, 61, & 72)	X	X	X	X	X	X
37	Hex Hd Bolt, Metric 8 x 30 (8 x 25 on SW32)			X			
37	Hex Hd Bolt, 5/16-18 x 1-3/4 (1-1/4 on SW32-14BV)	X	X		X	X	X
38	48182-01 WHEEL ASSY (INCL. 38A-38B) (FITS SW36, 48, 52, 61, 72)	X	X	X	X	X	X
38	48253 WHEEL ASSY (INCL. 38A-38B) (FITS SW32)	X					
38A	48182-01 TIRE, 13 X 6.50-6, 2-PLY FITS SW36,48,52,61,72	X	X	X	X	X	X
38B	48182-03 RIM&BRG ASSY (INCL. 39) FITS SW36,48,52,61,72	X	X	X	X	X	X
38C	48253-02 TIRE, 13 X 5.00-PLY FITS SW32 ONLY	X					
38D	48253-03 RIM&BRNG ASSY (INCL. 39) FITS SW32 ONLY	X					

\* Common hardware which should be purchased locally. All bolts Grade 5 plated, all other fasteners zinc plated.

ENGINE DECK CONTINUED ON FOLLOWING PAGE



## ENGINE DECK CONT'D

REF. PART NO.	DESCRIPTION	14BV	14KH	13KA	18KH	18EKH	20EKH
39	48193-02 Wheel Bearing NWC ( OD 1.984 - 1.980)	X	X	X	X	X	X
39	48193-01 Wheel Bearing [ OD 2.000 - 2.005]	X	X	X	X	X	X
40	04042-05 Washer, 1-1/16 x 1-3/4 x 12 ga.	X	X	X	X	X	X
40A	04041-14 Washer, 1-1/16 x 1-1/2 x 18 ga.	X	X	X	X	X	X
41	04050-08 Retaining Ring, 1" Ext.-"E"	X	X	X	X	X	X
42	48200 Pulley, Wheel Drive	X	X	X	X	X	X
43	43088 Spacer, Wheel Pulley	X	X	X	X	X	X
44	48209 Brake Drum	X	X	X	X	X	X
45	Hex Hd. Bolt, 5/16-18 x 1-1/2	X	X	X	X	X	X
46	04003-03 Short Square Neck Crg. Bolt, 3/8-16 x 2	X	X	X	X	X	X
47	Hex Nut, 5/16-18 Elastic Stop	X	X	X	X	X	X
48	04003-05 Short Sq. Neck Crg. Bolt, 3/8-18 x 1-1/2	X	X	X	X	X	X
49	45145 Battery Box					X	X
50	42330 Bracket, Idler Pulley				X	X	X
51	43063 Spacer				X	X	X
52	04041-11 Washer, 13/32 x 1-1/2 x 7 ga.				X	X	X
53	42361 Battery Clamp					X	X
54	42024 Battery Cover					X	X
55	48099 Battery Cover Pad					X	X
56	Carrage Hd Bolt, 1/4-20 x 6					X	X
63	Hex Hd Bolt, 3/8-16 x 2				X	X	X
64	48030 Clamp, Fuel Hose				X	X	X
65	48257 Pipe Cap				X	X	X
66	48254 Pipe 4" Nipple				X	X	X
68	04022-01 Wing Nut, 1/4-20 elastic stop					X	X
69	48015 Battery					X	X
70	Hex Hd. Bolt, 3/8-16 x 1 1/4"					X	X
71	Hex Nut, 5/16-18	X	X	X	X	X	X
72	Lockwasher, 5/16	X	X	X	X	X	X
73	44037 Ball Scraper	X	X	X	X	X	X

\* Common hardware which should be purchased locally. All bolts Grade 5 plated, all other fasteners zinc plated.

## PEERLESS 700

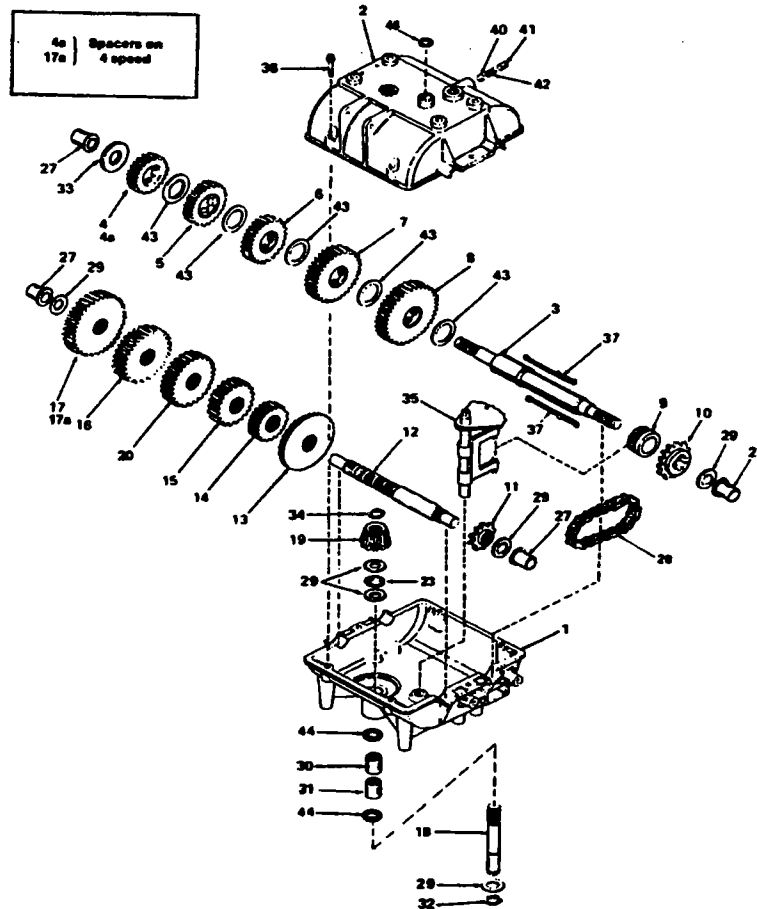

### PEERLESS TRANSMISSION MODEL 700-026

REF. PART NO. NO.	DESCRIPTION	ALL UNITS	REF. PART NO. NO.	DESCRIPTION	ALL UNITS
1 770061	Case, Transmisson	x	20 778240	Gear, Spur (18 teeth)	x
2 772083	Cover, Transmission	x	23 780071	Bearing, Thrust	x
3 776217	Shaft, Output & Brake	x	27 780105A	Bushing, Flanged	x
4 778123A	Gear, Spur (25 teeth)	x	28 786081	Chain, Roller (No.41 chain,24 links)	x
5 778124A	Gear, Spur (30 teeth)	x	29 780072	Washer, Thrust	x
6 778239	Gear, Spur (32 teeth)	x	30 780086	Bearing, Needle	x
7 778125	Gear, Spur (35 teeth)	x	31 780142	Bearing, Needle	x
8 778146A	Gear, Spur (37 teeth)	x	32 792035	Ring, Retaining	x
9 784266	Gollar, Shift	x	33 780139	Washer, Thrust	x
10 786083	Sprocket (18 teeth)	x	34 788040	Ring, Retaining	x
11 786082	Sprocket (9 teeth)	x	35 784267	Rod & Fork Assy., Shift	x
12 776134	Shaft, Counter	x	36 792073	Screw, Flanged Hexhd. tf, 1/4-20x1-1/4	x
13 778154	Gear, Bevel (42 teeth)	x	37 792089A	Key	x
14 778145	Gear, Spur (12 teeth)	x	40 792077	Ball, Steel, 5/16"	x
15 778151	Gear, Spur (15 teeth)	x	41 792078	Screw, Set 3/8-16 x 3/8	x
16 778126A	Gear, Spur (20 teeth)	x	42 792079	Spring	x
17 778127A	Gear, Spur (25 teeth)	x	43 780108	Washer, Thrust	x
18 776135	Shaft, Input	x	44 792001	"O" Ring	x
19 778178	Bevel Pinion, Input	x	46 788069	Seal, Square cut	x

## HANDLE ASSEMBLY

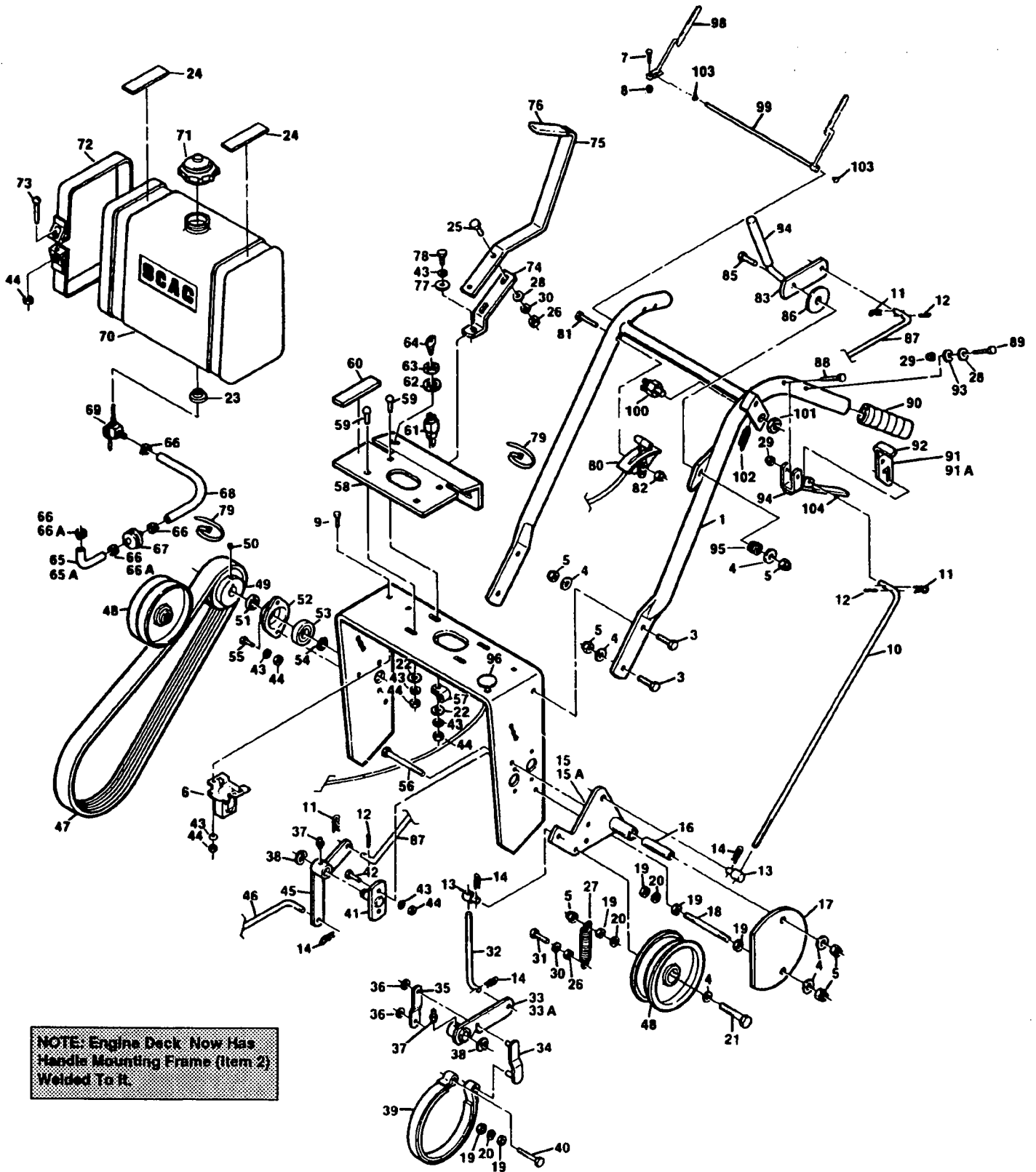

**NOTE: Engine Deck Now Has Handle Mounting Frame (Item 2) Welded To It.**

## HANDLE ASSEMBLY

REF. PART NO.	NO.	DESCRIPTION	14BV	14KH	13KA	18KH	18EKH	20EKH
<b>! ATTENTION LINES IN BOLD LETTERS INDICATE EXTRA IDENTIFICATION IS NEEDED !</b>								
1	45097	<b>HANDLE ASSY. FITS SW 32, 36, 48</b>	X	X	X			
1	45117	<b>HANDLE ASSY. FITS SW 52, 61, 72</b>	X	X	X	X	X	X
2	42249	<b>HANDLE MOUNTING FRAME FITS SW 32, 36, 48</b>	X	X	X			
2	42310	<b>HANDLE MOUNTING FRAME FITS SW 52, 61, 72</b>	X	X	X	X	X	X
3	*	Hex Hd. Bolt, 3/8-16 x 1	X	X	X	X	X	X
4	*	Washer, 25/64 x 15/16 x 12 ga.	X	X	X	X	X	X
5	*	Hex Nut, 3/8-16 Elastic Stop	X	X	X	X	X	X
5	48016	Solenoid					X	X
7	*	Hex Head Bolt 5/16-18 1 1/4"	X	X	X	X	X	X
8	*	5/16-16 Elastic Stop Nut	X	X	X	X	X	X
9	*	Bolt, Hex Hd. 1/4-20 x 1/2					X	X
10	44004	Control Rod, Steering	X	X	X	X	X	X
11	04062-02	Hair Pin, Small	X	X	X	X	X	X
12	*	Cotter Pin, 3/32 x 3/4	X	X	X	X	X	X
13	43092	Swivel Joint	X	X	X	X	X	X
14	04062-01	Hair Pin, Large	X	X	X	X	X	X
15	45091-01	Idler Bracket, RH	X	X	X	X	X	X
15A	45091-02	Idler Bracket, LH	X	X	X	X	X	X
16	43092	Idler Sleeve	X	X	X	X	X	X
17	42283	Belt Guard	X	X	X	X	X	X
18	04004-01	Support Belt Guard	X	X	X	X	X	X
19	*	Hex Nut, 3/8-16	X	X	X	X	X	X
20	*	Lockwasher, 3/8 spring	X	X	X	X	X	X
21	*	Hex Hd. Bolt, 3/8-16 x 2-3/4	X	X	X	X	X	X
22	*	Flat Washer, 1/4	X	X	X	X	X	X
23	48309	Bushing	X	X	X	X	X	X
24	48292	Rubber Pads, (upper)	X	X	X	X	X	X
25	*	Hex Hd. Bolt, 5/16-18 x 1-1/4	X	X	X	X	X	X
26	*	Hex Nut, 5/16-18	X	X	X	X	X	X
27	48051	Spring, Idler Tension	X	X	X	X	X	X
28	*	Washer, 11/32 x 11/16 x 16 ga.	X	X	X	X	X	X
29	*	Hex Nut, 5/16-18 Elastic Stop	X	X	X	X	X	X
30	*	Lockwasher, 5/16 spring	X	X	X	X	X	X
31	*	Hex Hd. Bolt, 5/16-18 x 1	X	X	X	X	X	X
32	44005	Brake Rod	X	X	X	X	X	X
33	45092-01	Brake Lever, RH	X	X	X	X	X	X
33A	45092-02	Brake Lever, LH	X	X	X	X	X	X
34	45093	Brake Link	X	X	X	X	X	X
35	42254	Brake Link Plate	X	X	X	X	X	X
36	04024-01	Nut, 3/8 push-on	X	X	X	X	X	X
37	48114-01	Grease Fitting, Straight, 1/4-28	X	X	X	X	X	X
38	04050-01	Retaining Ring, 5/8 Ext.-"E"	X	X	X	X	X	X
39	48210	Brake Band	X	X	X	X	X	X
40	*	Hex Hd. Bolt, 3/8-16 x 2	X	X	X	X	X	X
41	45094	Belt Crank Pivot Wld.	X	X	X	X	X	X
42	*	Hex Hd. Bolt, 1/4-20 x 1	X	X	X	X	X	X
43	*	Lockwasher, 1/4 spring	X	X	X	X	X	X
44	*	Hex Nut, 1/4-20	X	X	X	X	X	X
45	45277	Belt Crank, Clutch	X	X	X	X	X	X
46	44064	Blade Clutch Rod, Lower	X	X	X	X	X	X
47	48202A	Belt, Wheel Drive	X	X	X	X	X	X
48	48198	Idler Pulley, Wheel Drive	X	X	X	X	X	X
49	48199	Pulley, Jackshaft (incl. 50)	X	X	X	X	X	X
50	*	Setscrew, Hex Sct. Krrl. Cup Pt. 5/16-18 (nylock)	X	X	X	X	X	X
51	43098	Spacer, Jackshaft Pulley	X	X	X	X	X	X
52	48223	Flange, Jackshaft Bearing	X	X	X	X	X	X
53	48224	Bearing, Jackshaft	X	X	X	X	X	X
54	04050-09	Retaining Ring, 5/8 Ext.-Basic	X	X	X	X	X	X
55	*	Hex Head Bolt, 1/4-20 x 3/4	X	X	X	X	X	X
56	*	Hex Head Bolt, 3/8-16 x 4	X	X	X	X	X	X

\* Common hardware which should be purchased locally. All bolts grade 5 plated, all other fasteners zinc plate.

HANDLE ASSEMBLY CONTINUED ON NEXT PAGE

## HANDLE ASSEMBLY CONT'D

REF. PART NO.	NO.	DESCRIPTION	14BV	14KH	13KA	18KH	18EKH	20EKH
<b>! ATTENTION LINES IN BOLD LETTERS INDICATE EXTRA IDENTIFICATION IS NEEDED !</b>								
57	48030-01	Clamp	X	X	X	X	X	X
58	46431	Shifter Plate w/Decal	X	X	X	X	X	X
59	-	Carriage Bolt, 1/4-20 x 1	X	X	X	X	X	X
60	48205	Rubber Pad (lower)	X	X	X	X	X	X
61	48171	Key Switch	X	X	X	X	X	X
61	48017	Key Switch	X	X	X	X	X	X
62	48017-03	Lockwasher, 5/8 Internal Tooth	X	X	X	X	X	X
63	48017-04	Hex Nut, 3/8-32	X	X	X	X	X	X
64	48017-02	Key, Ignition	X	X	X	X	X	X
65	48058-02	Fuel Hose (KH only) 1/4 ID x 14 1/8				X	X	X
66	48059-01	Clamp, Fuel Hose	X	X		X	X	X
66a	48059-02	Clamp, Fuel Hose (Kawasaki Only)			X			
67	48057-02	Fuel Filter			X			
68	48058-05	Fuel Hose, 1/4 ID x 17	X	X	X	X	X	X
69	48300	Valve, Fuel Shut Off	X	X	X	X	X	X
70	48174	Fuel Tank Assy. (Incl Decals 23, 69)	X	X	X	X	X	X
71	48311	Fuel Tank Cap	X	X	X	X	X	X
72	42369	Strap, Fuel Tank	X	X	X	X	X	X
73	-	Machine Screw, 1/4-20 x 2 Round Hd. Slotted	X	X	X	X	X	X
74	42388	Shifter Lever	X	X	X	X	X	X
75	46207	Shift Lever Assy. (Incl. 76)	X	X	X	X	X	X
76	48215	Grip, Shift Lever	X	X	X	X	X	X
77	04043-01	Washer, 17/64 x 7/8 x 1/8 HT	X	X	X	X	X	X
78	04001-55	Hex Head Bolt, 1/4-28 x 3/4 Grade 5	X	X	X	X	X	X
79	48024-01	Cable Tie	X	X	X	X	X	X
80	48206	Throttle Control			X			
80	48385	Throttle Control	X	X				
80	48266	Throttle Control				X	X	X
81	-	Hex Head Bolt, 1/4-20 x 2	X	X	X	X	X	X
82	-	Hex Nut, 1/4-20 Elastic Stop	X	X	X	X	X	X
83	46090	Blade Clutch Lever Assy. (Incl. 104)	X	X	X	X	X	X
84	48326	Grip, Lever	X	X	X	X	X	X
85	-	Hex Head Bolt, 3/8-16 x 1-3/4	X	X	X	X	X	X
86	04041-10	Washer, 3/8 x 2 x 15 ga.	X	X	X	X	X	X
87	44002	Bolt Clutch Rod, Upper	X	X	X	X	X	X
88	-	Hex Head Bolt, 5/16-18 x 2-1/4	X	X	X	X	X	X
89	-	Hex Head Bolt, 5/16-18 x 2	X	X	X	X	X	X
90	48159	Grip, Handle	X	X	X	X	X	X
91	46083-01	Neutral Latch Assy. RH (Incl. 92)	X	X	X	X	X	X
91A	46083-02	Neutral Latch Assy. LH (Incl. 92)	X	X	X	X	X	X
92	48324-01	Grip, Neutral Latch - RH	X	X	X	X	X	X
92	48324-02	Grip, Neutral Latch - LH	X	X	X	X	X	X
93	04032-01	Curved Spring Washer	X	X	X	X	X	X
94	46089	Steering Lever Assy. (Incl. 84)	X	X	X	X	X	X
95	48050	Spring, Compression	X	X	X	X	X	X
96	48091	Choke Control				X	X	X
97	-	Set Screw, 1/4-28 x 1/4" Knurled cup point	X	X	X	X	X	X
98a	45141	Safety Interlock Hand Grip - RH	X	X	X	X	X	X
99	45417	<b>OPERATOR PRESENCE HAND GRIP L.H. &amp; ROD (FOR 16")</b>	X	X	X			
99	45142	<b>OPERATOR PRESENCE HAND GRIP L.H. &amp; ROD (FOR 20")</b>		X		X	X	X
100	48021	Switch Interlock (gold colored)	X	X	X	X	X	X
101	04026-01	Hex Nut, 9/16-18 spring steel	X	X	X	X	X	X
102	48313	Spring, Grip Return	X	X	X	X	X	X
103	48312	Bushings	X	X	X	X	X	X
104	48144	Grip, Steering Levers	X	X	X	X	X	X
NS	48293	Wire Harness, electric start					X	X
NS	48237	Wire Harness, manual start	X	X	X	X		
NS	48287	Wire Harness, Kohler adapter for use with 48237		X		X		

\* Common hardware which should be purchased locally. All bolts grade 5 plated, all other fasteners zinc plate.

## ELECTRIC START ELECTRICAL SYSTEM

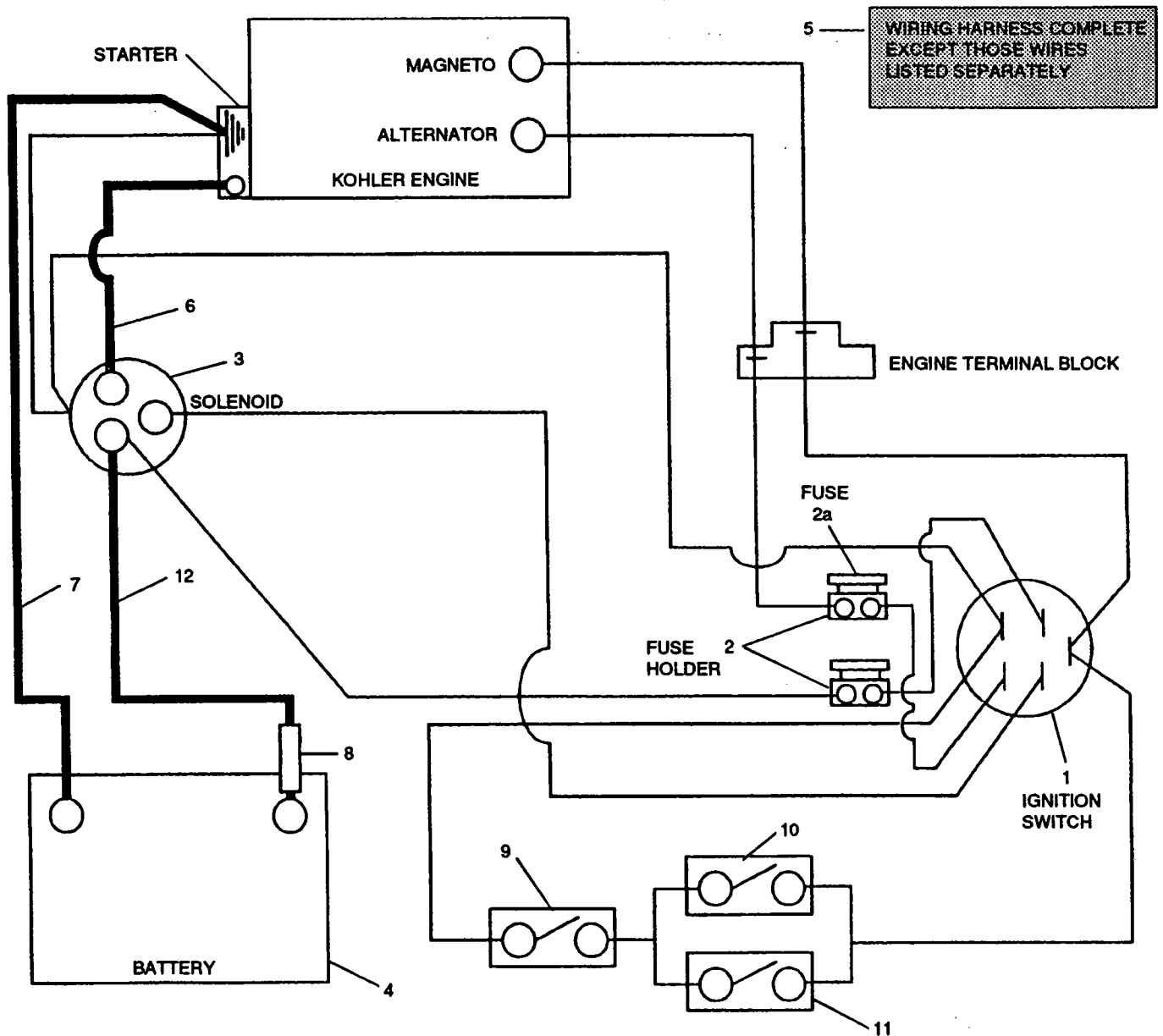

Ref. No.	Part Number	Description	SW 20KHE
1	48017	Key Switch	x
2	48297	Fuse Holder	x
2a	48298	Fuse 20 Amps	x
3	48016	Solenoid	x
4	48015	Battery may be purchased locally (U9-LM)	x
5	48611	Wiring Harness Complete	x
6	48029-03	Battery Cable - 13-3/4" Red	x
7	48029-10	Battery Cable - 20" Black	x
8	48126	Rubber Boot	x
9	48021	Switch, Handle Interlock N.C.	x
10	48305	Switch, Cutter Drive Interlock N.C.	x
11	48231	Switch, Neutral Interlock N.O.	x
12	48029-02	Battery Cable - 31.5" Red	x

## WIRING DIAGRAM FOR MANUAL START

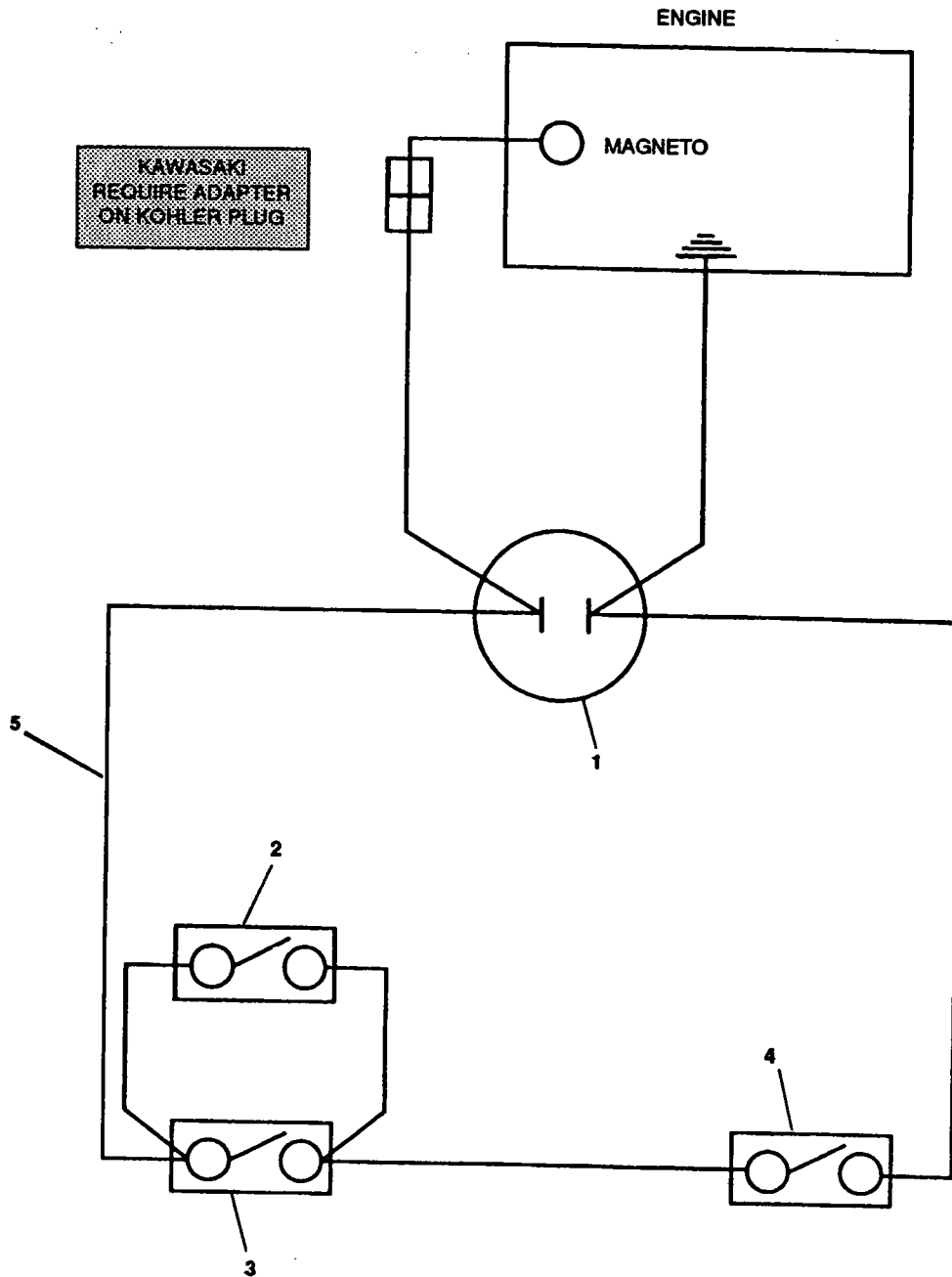

Ref. No.	Part Number	Description
1	48609	Switch, Ignition
2	48231	Switch, Transmission Neutral Safety
3	48305	Switch, Clutch Safety
4	48021	Switch, Presence Control Safety
5	48610	Wire Harness

## REPLACEMENT DECALS



48314  
Decal - Scag's Logo  
(Located On Cutter Deck Cover - Top Surface)

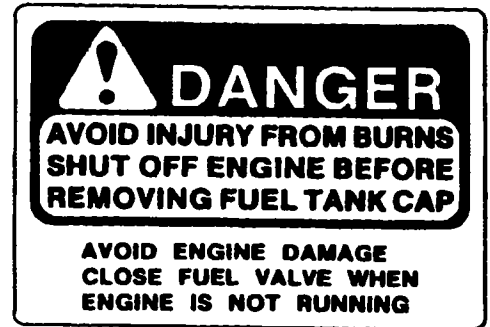

48281  
Decal - Operator Warning  
Fuel Fill  
(Located On Top of Fuel Tank)



48072  
Decal - Heavy Duty Commercial  
(Located On Cutter Deck Cover - Front Wall)



48216 - 4 SPD  
48332 - 5SPD  
Decal - Shift Index  
(Located On Shifter Plate - Above Shift Lever)



48079  
Decal - Key Switch  
(Located Near Keyswitch)



72 48327  
61 48320  
52 48319  
48 48318  
36 48316



48073  
Decal - Danger, Rotating Blades  
(Located On Cutter Deck Cover Near Discharge Chute)



48712  
Decal - Caution Belt Cover  
(Located On Cutter Deck Top Surface)



48071  
Decal - O.P.E.I. Safety  
(Located On Cutter Deck Near Discharge Chute)



48713  
Decal - Caution Read Operator Manual  
(Located Top Of Hydraulic Reservoir)



## WARNING

If incorrectly used, this machine can cause severe injury. Those who use and maintain the machine should be trained in its proper use, warned of its dangers, and should read the entire manual before attempting to set up, operate, adjust or service the machine.

## LIMITED WARRANTY-COMMERCIAL EQUIPMENT

This warranty extends to the original retail purchaser only and commences on the date of original retail purchase.

Any part of the Scag commercial mower manufactured by Scag and found in the reasonable judgment of Scag to be defective in material or workmanship, will be repaired or replaced by an Authorized Scag Service Dealer without charge for parts and labor.

The Scag mower including any defective part must be returned to an Authorized Scag Service Dealer within the warranty period. The expense of delivering the mower to the dealer for warranty work and the expense of returning it back to the owner after repair or replacement will be paid for by the owner. Scag's responsibility in respect to claims is limited to making the required repairs or replacements, and no claim of breach of warranty shall be cause for cancellation or rescission of the contract of sale of any Scag mower. Proof of purchase will be required by the dealer to substantiate any warranty claim. All warranty work must be performed by an Authorized Scag Service Dealer.

This warranty is limited to one year from the date of original retail purchase for any Scag mower that is used for commercial purposes, or any other income-producing purpose (90 days for rental use).

This warranty does not cover any mower that has been subject to misuse, neglect, negligence, or accident, or that has been operated in any way contrary to the operating instructions as specified in the Technical Manual. The warranty does not apply to any damage to the mower that is the result of improper maintenance, or to any mower or parts that have not been assembled or installed as specified in the Technical Manual.

The warranty does not cover any mower that has been altered or modified so as to adversely affect the product's operation, performance or durability or that has been altered or modified so as to change the intended use of the product. In addition, the warranty does not extend to repairs made necessary by normal wear, or by the use of parts or accessories which, in the reasonable judgment of Scag, are either incompatible with the Scag mower or adversely affect its operation, performance or durability. This warranty does not cover engines, electric starters, batteries, belts and tires which are warranted separately by their manufacturer and for a different period of time.

Scag Power Equipment reserves the right to change or improve the design of any mower without assuming any obligation to modify any mower previously manufactured.

All other implied warranties are limited in duration to the one (1) year warranty period or ninety (90) days for mowers used for rental purpose. Accordingly, any such implied warranties including merchantability, fitness for a particular purpose, or otherwise, are disclaimed in their entirety after the expiration of the appropriate one year or ninety day warranty period. Scag's obligation under this warranty is strictly and exclusively limited to the repair or replacement of defective parts and Scag does not assume or authorize anyone to assume for them any other obligation. Some states do not allow limitations on how long an implied warranty lasts, so the above limitation may not apply to you.

Scag assumes no responsibility for incidental, consequential or other damages including, but not limited to, expense for gasoline, expense of delivering the mower to an Authorized Scag Service Dealer and expense of returning it back to the owner, mechanic's travel time, telephone or telegram charges, rental of a like product during the time warranty repairs are being performed, travel, loss or damage to personal property, loss of revenue, loss of use of the mower, loss of time or inconvenience. Some states do not allow the exclusion or limitation of incidental or consequential damages. So the above limitation or exclusion may not apply to you.

This warranty gives you specific legal rights, and you may also have other rights which vary from state to state.

**PLEASE BE CAREFUL**

1. Keep all shields in place, especially grass discharge.
2. Stop machine and remove spark plug wire to adjust or service.
3. When mechanism becomes clogged, stop engine before cleaning.
4. Keep hands, feet and clothing away from power-drive parts.
5. Keep off implement unless seat or platform is provided.
6. Keep others off.

**FAILURE TO FOLLOW CAUTIOUS OPERATING PRACTICES MAY RESULT IN SERIOUS BODILY INJURY. BESIDES, WE WOULD LIKE YOU TO CONTINUE TO ENJOY AND PROFIT BY USING OUR PRODUCTS.**

**OWNER REFERENCE**

MODEL NUMBER \_\_\_\_\_

SERIAL NUMBER \_\_\_\_\_

ENGINE MODEL \_\_\_\_\_

SERIAL NUMBER \_\_\_\_\_